

# INSTRUCTIONS MANUAL

GB 12/2008

## MANUAL TOMATO SLICER model 2 CT5/6/10

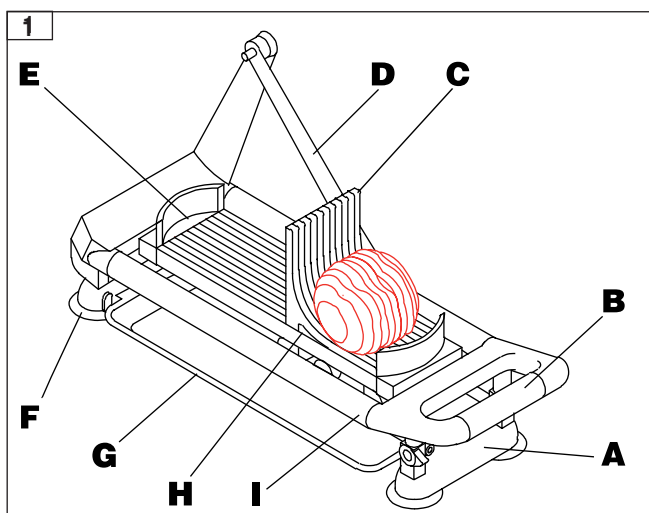

### INTRODUCTION

• These manual tomato slicers can cut tomatoes into 5, 6 or 10 slices (depending on model). The tomatoes are cut progressively so that only a little of their juice is lost, they are not crushed and they retain their original shape after cutting.



- A Body
- B Hinged frame with handle
- C Carriage
- D Carriage control lever
- E Blade block and tensioners
- F Suction cups
- G Juice and seed collection tray
- H Carriage retaining screw
- I Rubber stops

- Gross weight packaged : 3.3 kg
- Net weight equipped : 3 kg
- Dimensions of packaging (mm) : 440 x 245 x 150

Dimensions of slicer:

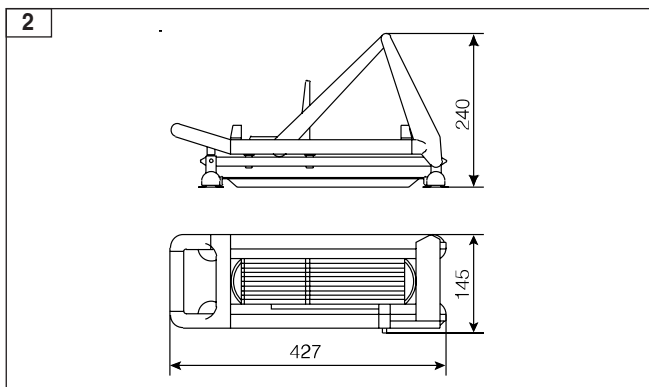

### USE

#### • Before use:

- Check that the cutting equipment is clean (blade block and carriage), see § Cleaning and removal.

#### • Using the cutter

1) Place the tomato slicer on the edge of the table, its 4 suction cups provide sufficient adhesion on smooth surfaces.

2) Slide the tray under the carriage to collect the juice and seeds.



3) Raise the hinged frame using the handle to its upper stop and place the tomato in the dished cavity of the body.

4) Lower the frame firmly until it reaches the lower stop.

5) Remove the sliced tomato.

*Note: In normal use, around 20 tomatoes can be sliced in a minute.*

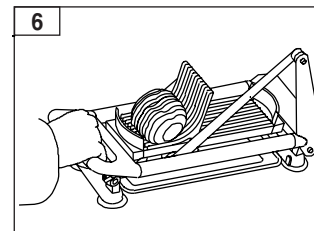
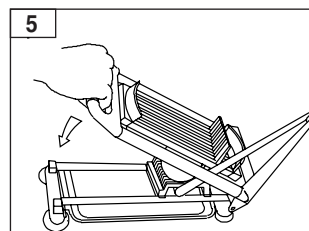
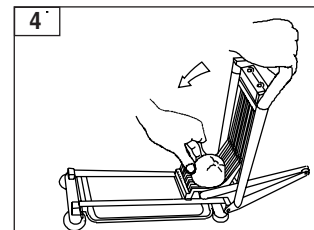
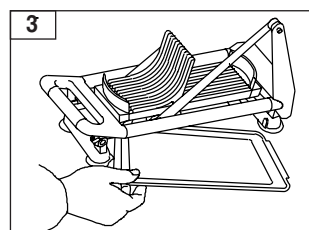

### CLEANING, HYGIENE

#### • Removing the carriage:

- Raise the hinged frame and unscrew the carriage retaining screw in an anticlockwise direction

- Slide the carriage forwards to remove it from the body.

#### • Cleaning:

- The grooves of the carriage can be cleaned with a brush.

- The rest of the tomato slicer and the tray can be cleaned with a sponge soaked in detergent - disinfectant.



Do not use abrasive detergents, which could scratch the surfaces, or chlorine based products which may dull the aluminium.

- Rinse all parts under running water. 9-10

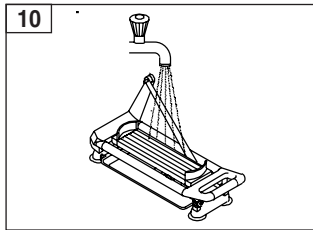
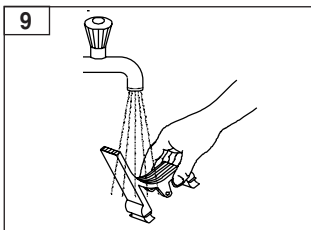
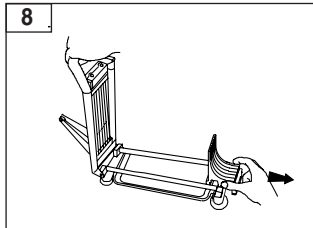
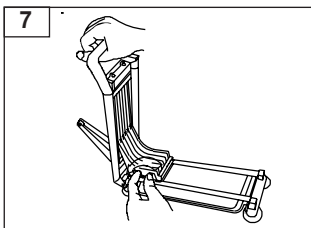

Do not clean with a dishwasher.

- Check that the carriage grooves and the blades are clean.
- Carefully wipe dry the slicer and fit the carriage.



When cleaning, handle the slicer carefully, to avoid cutting yourself with the blades.

#### • Food hygiene:

The machine is made from materials that conform to the following regulations and standards:

- Directive 89/109/EEC: Materials and objects in contact with foodstuffs,
- Directive 89/128/EEC: Plastics in contact with foodstuffs
- EN 601-1992 standard: Cast aluminium objects in contact with foodstuffs.

The surfaces of the food area are smooth and easy to clean. Use detergents that are approved for food hygiene and respect the instructions for their use.

### MAINTENANCE

- The tomato slicer only requires a minimum amount of maintenance.
- **Periodically** check:
  - The cutting edge of the blades. Sharpen if necessary with a small flat file.
  - The tension of the blades when the slices are of irregular thickness.
  - Oil the pins of the handle with food compatible oil.
- **To tension the blades:** 11
  - Progressively tighten the 2 screws at the rear (8 mm Allen key).
- **To change the blade block:** 12
  - Unscrew the 4 screws at the front and rear which retain and tension the blade block (8 mm Allen key).

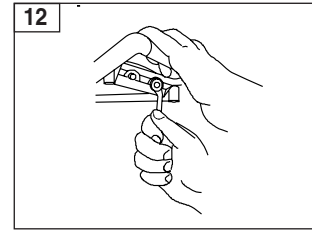
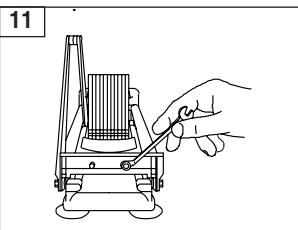

#### • Address for service requirements:

We advise you to contact the dealer who sold you the machine.



For any information or orders for spare parts, specify the type of machine.

The manufacturer reserves the right to modify and make improvements to the products without giving prior warning.

Dealer's stamp

Date of purchase : .....

### PARTS LIST - EXPLODED VIEW

Item	Qty	Code	Description
<b>After-sales sub-assemblies and parts</b>			
1	1	0D2453	Support body assembly
2	1	0D2454	Frame assembly
3	1	653362	Carriage screw assembly (5 mm cut)
	1	653099	Carriage screw assembly (6 mm cut)
	1	653444	Carriage screw assembly (10 mm cut)
4	1	0D0773	Control arm assembly
5	1	653104	Blade block (5 mm)
	1	653100	Blade block (6 mm)
	1	653107	Blade block (10 mm)
6	1	0D0772	Set of 4 suction cups
7	1	0D3773	Collection tray
8	1	0D0771	Slide rail kit
9	1	0D2455	Rubber stop

